

AZV 160 CN

Trapano verticale a doppia testa automatico a controllo numerico

Double head vertical drilling machine CN

Doppel-Seitege Vertikal-Bohrmaschine CN

Perceuse verticale a double tete CN

Taladro vertical a doble cabezal CN

AZV 160 CN

Caratteristiche tecniche

Technical features

Technische Eigenschaften

Caractéristiques techniques

Características técnicas



Altezza area di lavoro	Working area height	Arbeitshöhe	Hauteur zone de travail	Altura área de trabajo	1600 mm 63 in
Numero di teste	Number of heads	Anzahl der Kopfe	Tetes de perçage	Número de cabezales	2
Spessore vetro	Glass Thickness	Glasdicke	Épaisseur du verre	Espesor de vidrio	3-20 mm 1/8 - 25/32 in
Diametro fori	Hole Diameters	Lochdurchmesser	Diametre de perçage	Diámetro del agujero	3-100 mm 1/8 - 4 in
Pezzo minimo lavorabile	MIN Workable piece	Min. Glasgröße	Dimensions mini des volumes de verre	Medida mínima de pieza	250 x 100 mm 10 X 4 in
Potenza Installata	Installed Power	Leistungsaufnahme	Puissance installée	Potencia instalación	9 kW
Velocità massima mandrino	Spindle MAX Speed	Motorgeschwindigkeit	Vitesse de rotation maximum	Velocidad máxima de rotación	9000 rpm
Peso	Weight	Gewicht	Poids	Peso	1650 Kg
Lunghezza foretto	Tool Length	Werkzeuglänge	Longueur d'outi	Longitud broca	75 mm x 1/2 gas 3 inches x 1/2 gas
Misurazione automatica punta	Automatoc drill measurement	Automatische Abmessungen Bohrer	Mesure automatique du foret	Medición automática de las brocas	Yes

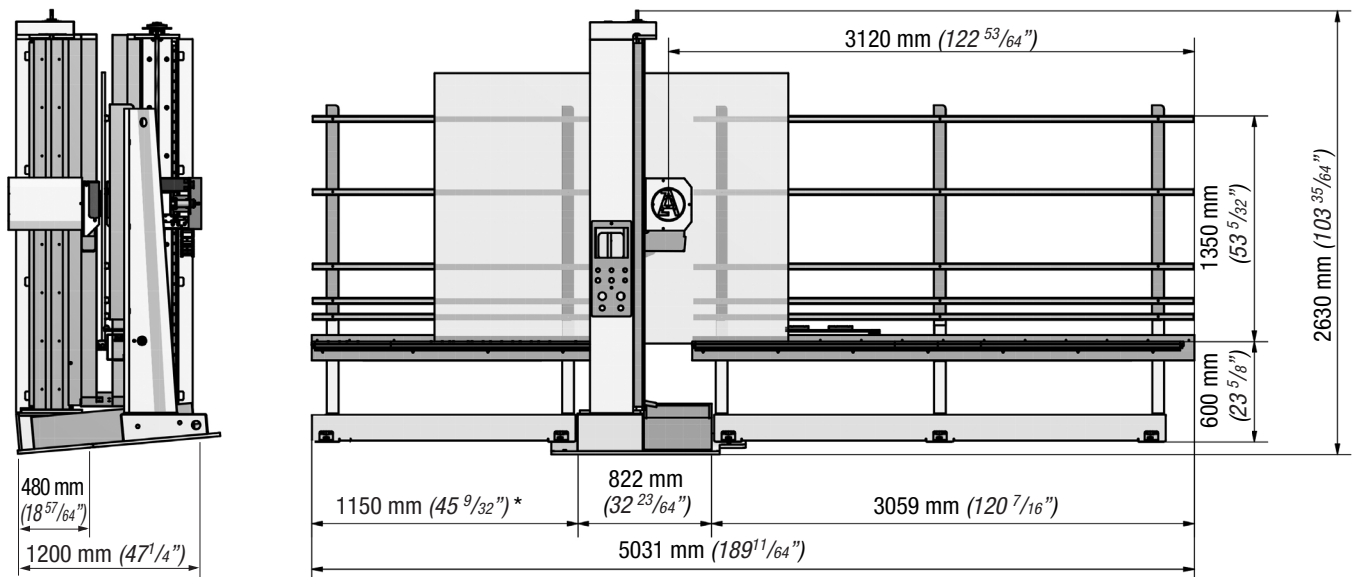

* Optional on demand 2990 mm (117 23/32") - Tot L = 6871 mm (270 33/64")